

**INFORMATION**

The Joker News 200 system was designed specifically for the fast pace and quick set ups of news coverage. The ultra fast re-strike lamp starter assures quiet and immediate lamp ignition and re-ignition. This innovative fixture has retained the qualities of the Joker-bug system, offering two fixtures in one: an Omni-directional fixture and a directional focus-able open face Flood.

The Joker News 200 requires virtually no set up time, the focusing of the parabolic reflector changes the beam pattern from Spot to Flood in a 3 to 1 ratio, achieving beam angles from 16 to 45 degrees. Used without optics (News Beamer detached) the Joker News becomes a Bug-Lite. This very open source is ideal to fill evenly a Lightbank or a Lantern making it the perfect light for interviews. Its lightweight allows it to hang safely at the end of a boom arm.

The system will travel and operate in 110 and 240Volt environments as well as 28.8 (2x 14.4 camera batteries) and 30 Volt.

**SPECIFICATIONS**

**Lamp Housing:** Aluminum casting, high temperature black epoxy, striker compartment is light gray epoxy.

**NEWS BEAMER:** Solid one piece machined aluminum with replaceable ears. Clear anodized. Focusing by very short radial action. Integrated design.

**Safety Glass Beaker:** Borosilicate UV filter tempered.

**Yoke:** 5/8" Baby size receptacle, Aluminum casting black epoxy finish. Large brake area for use of front end lightbanks, speed rings, louvers and lanterns.

**Lamp:** MSR 200 HR, 5600 Kelvin, 200 hours life.

**Power Supply:** Electronic, square wave flicker free AC input: 90-265 Volt 50 or 60 Hz. DC Input: 30 Volt or 14.4 Volt. Dual function ON/OFF push button switch and completely silent (convection cooled). Connectors: Veam quarter turn quick locking.

**Extension Cable:** 25ft and 9ft attached to the head.

**Reflector:** 4 3/4" diameter stippled parabolic electrolytically coated.

**Accessory size:** 6 5/8"

**Accessories:** Barndoor, Dicroic, Scrims.



**PHOTOMETRICS**

dis.	Spot fc..	Diam. ft.	Flood fc.	Diam. ft.
3'	8400	0.8	2800	2.5
6'	2100	1.7	700	5

**DIMENSIONS**

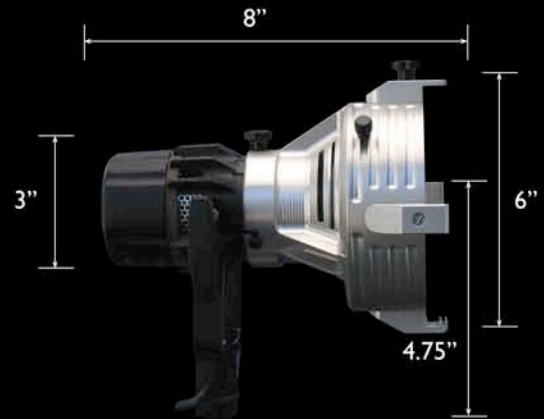

Weight: 3.5 lbs (1.59 kg)



Weight: 4.4 lbs (2 kg)