

**INFORMATION**

The Evolution 200 is designed to be a simple solution to the everyday fast paced, budget conscious dilemma of lighting for News! Similar to our other News fixtures, this light allows for quick and easy setups.

The focusing openface matt reflector allows you to adjust the beam of light from spot to flood with a quick turn of the Beamer. No lenses needed! The most compact of our News beamers, yet still permits the light to be versatile like our others having the ability to convert from the openface directional light to a Bug-lite (News Beamer detached) that is the ideal to evenly fill a Lightbank or Lantern. Perfect for interviews, product shots, training videos, Schools, and much more... The Evolution 200 is available with the standard AC Electronic Ballast or with our NEW 200w AC/DC ballasts. All are 110v/220v 50/60 hz. Also will work with our 200 & 400 slimverters.

Available in a variety of kits!

**SPECIFICATIONS**

**Lamp Housing:** Aluminum casting, high temperature black epoxy, striker compartment is light gray epoxy.

**NEWS BEAMER:** Solid one piece machined aluminum with replaceable ears. Clear anodized. Focusing by very short radial action. Integrated design.

**Safety Glass Beaker:** Borosilicate UV filter tempered.

**Yoke:** 5/8" Baby size receptacle, Aluminum casting black epoxy finish. Large brake area for use of front end lightbanks, speed rings, louvers and lanterns.

**Lamp:** MSR 200 HR, 5600 Kelvin, 200 hours life.

**Power Supply:** Electronic, square wave flicker free AC input: 90-265 Volt 50 or 60 Hz. DC Input: 30 Volt or 14.4 Volt. Dual function ON/OFF push button switch and completely silent (convection cooled). Connectors: Veam quarter turn quick locking.

**Extension Cable:** 25ft and 9ft attached to the head.

**Reflector:** 4 3/4" diameter stippled parabolic electrolytically coated.

**Accessory size:** 6 5/8"

**Accessories:** Barndoor, Dicroic, Scrims.



**PHOTOMETRICS**

dis.	Spot fc..	Diam. ft.	Flood fc.	Diam. ft.
3'	8400	0.8	2800	2.5
6'	2100	1.7	700	5

**DIMENSIONS**

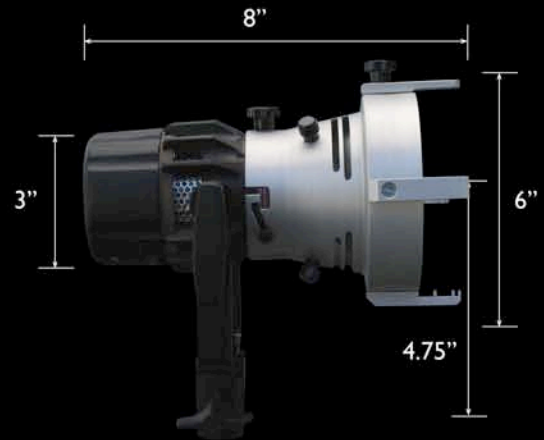

Weight: 3.5 lbs (1.59 kg)



Weight: 4.4 lbs (2 kg)